



Typical Single-Story Framing Section

This information bulletin describes the items how to prepare a typical framing section for single-story residential construction. One or more framing sections will be required as part of plans submitted for approval prior to permit issuance. Additional information on the preparation of plans for a single dwelling unit can be found in "California Building Code".

1. What is a Framing Section?

The California Building Code specifies that, for single-family residential construction, all framing members shall be "anchored, tied and braced so as to develop the strength and rigidity necessary for the purposes for which they are to be used". A framing section is a cutaway view of the proposed construction that is used to show how these requirements are met. Depending on the design of your project, you may need to include more than one framing section. You must clearly show deviations in your sections wherever they occur.

Included in this bulletin are illustrations showing several typical framing sections and details. The illustrations depict conventional wood construction. All framing sections should be cross-referenced on the building plans using the floor, foundation and/or roof framing views. See Figure 1.

All framing sections should include enlarged views that detail roof and floor connections as well as lumber and footing sizes.

2. Typical Framing Sections

Included in this bulletin are the following typical cross section views:

Figure 2 illustrates a framing section, slab floor with ceiling joist

Figure 3 illustrates a framing section, slab floor with vaulted ceiling

Figure 4 illustrates a framing section, raised floor with ceiling joists

Figure 5 illustrates a framing section, slab floor with shed roof

3. Typical Details

Included in this bulletin are the following typical details:

Detail A illustrates a typical roof ridge connection when using rafters and ceiling joists (from Figure 4)

Detail B illustrates a typical ridge beam connection when rafters are load bearing and ceiling joists will not be used (from Figure 3)

Detail C illustrates a typical roof connection showing rafters and ceiling joists attached to bearing walls (from Figures 2 and 4)

Detail D illustrates a typical roof connection showing a vaulted ceiling without ceiling joists attached to bearing walls (from Figure 3)

Detail E illustrates a typical shed roof connection attached to bearing walls (from Figure 5)

Detail F illustrates a typical bearing wall connection to a continuous footing with slab floor construction (from Figures 2, 3 and 5)

Detail G illustrates a typical bearing wall connection to a continuous footing with raised floor construction (from Figure 4)

Detail H illustrates a typical girder construction to an interior pad footing for raised floor construction (from Figure 4)

4. Span Tables

TABLE 2308.10.3 (2)
RAFTER SPANS FOR COMMON LUMBER SPECIES
(Roof Live Load = 20 pounds per square foot, ceiling not attached to rafters, L/Δ = 240)

RAFTER SPACING (inches)	SPECIES AND GRADE	DEAD LOAD = 10 pounds per square foot					DEAD LOAD = 20 pounds per square foot					
		2 x 4	2 x 6	2 x 8	2 x 10	2 x 12	2 x 4	2 x 6	2 x 8	2 x 10	2 x 12	
		Maximum rafter spans										
		(ft. in.)	(ft. in.)	(ft. in.)	(ft. in.)	(ft. in.)	(ft. in.)	(ft. in.)	(ft. in.)	(ft. in.)	(ft. in.)	(ft. in.)
12	Douglas Fir-Larch SS	10-5	16-4	21-7	----	----	10-5	16-4	21-7	----	----	
	Douglas Fir-Larch #1	10-0	15-9	20-10	----	----	10-0	15-4	19-5	23-9	----	
	Douglas Fir-Larch #2	9-10	15-6	20-5	25-8	----	9-10	14-4	18-2	22-3	25-9	
	Douglas Fir-Larch #3	8-7	12-6	15-10	19-5	22-6	7-5	10-10	13-9	16-9	19-6	
16	Douglas Fir-Larch SS	9-6	14-11	19-7	25-0	----	9-6	14-11	19-7	24-9	----	
	Douglas Fir-Larch #1	9-1	14-4	18-11	23-9	----	9-1	13-3	16-10	20-7	23-10	
	Douglas Fir-Larch #2	8-11	14-1	18-2	22-3	25-9	8-6	12-5	15-9	19-3	22-4	
	Douglas Fir-Larch #3	7-5	10-10	13-9	16-9	19-6	6-5	9-5	11-11	14-6	16-10	
19.2	Douglas Fir-Larch SS	8-11	14-0	18-5	23-7	----	8-11	14-0	18-5	22-7	----	
	Douglas Fir-Larch #1	8-7	13-6	17-9	21-8	25-2	8-4	12-2	15-4	18-9	21-9	
	Douglas Fir-Larch #2	8-5	13-1	16-7	20-3	23-6	7-9	11-4	14-4	17-7	20-4	
	Douglas Fir-Larch #3	6-9	9-11	12-7	15-4	17-9	5-10	8-7	10-10	13-3	15-5	
24	Douglas Fir-Larch SS	8-3	13-0	17-2	21-10	----	8-3	13-0	16-7	20-3	23-5	
	Douglas Fir-Larch #1	8-0	12-6	15-10	19-5	22-6	7-5	10-10	13-9	16-9	19-6	
	Douglas Fir-Larch #2	7-10	11-9	14-10	18-2	21-0	6-11	10-2	12-10	15-8	18-3	
	Douglas Fir-Larch #3	6-1	8-10	11-3	13-8	15-11	5-3	7-8	9-9	11-10	13-9	

TABLE 2308.10.2 (2)
CEILING JOIST SPANS FOR COMMON LUMBER SPECIES
(Uninhabitable Attics with Limited Storage, Live Load = 20 pounds per square foot, L/Δ = 240)

CEILING JOIST SPACING (inches)	SPECIES AND GRADE	DEAD LOAD = 10 pounds per square foot			
		2 x 4	2 x 6	2 x 8	2 x 10
		Maximum ceiling joist spans			
		(ft. in.)	(ft. in.)	(ft. in.)	(ft. in.)
12	Douglas Fir-Larch SS	10-5	16-4	21-7	----
	Douglas Fir-Larch #1	10-0	15-9	20-1	24-6
	Douglas Fir-Larch #2	9-10	14-10	18-9	22-11
	Douglas Fir-Larch #3	7-8	11-2	14-2	17-4
16	Douglas Fir-Larch SS	9-6	14-11	19-7	25-0
	Douglas Fir-Larch #1	9-1	13-9	17-5	21-3
	Douglas Fir-Larch #2	8-9	12-10	16-3	19-10
	Douglas Fir-Larch #3	6-8	9-8	12-4	15-0
19.2	Douglas Fir-Larch SS	8-11	14-0	18-5	23-4
	Douglas Fir-Larch #1	8-7	12-6	15-10	19-5
	Douglas Fir-Larch #2	8-0	11-9	14-10	18-2
	Douglas Fir-Larch #3	6-1	8-10	11-3	13-8
24	Douglas Fir-Larch SS	8-3	13-0	17-1	20-11
	Douglas Fir-Larch #1	7-8	11-2	14-2	17-4
	Douglas Fir-Larch #2	7-2	10-6	13-3	16-3
	Douglas Fir-Larch #3	5-5	7-11	10-0	12-3

TABLE 2308.8 (2)
FLOOR JOIST SPANS FOR COMMON LUMBER SPECIES
(Residential Living Areas, Live Load = 40psf, L/Δ = 360)

JOIST SPACING (inches)	SPECIES AND GRADE	DEAD LOAD = 10 psf				DEAD LOAD = 20 psf			
		2 x 6	2 x 8	2 x 10	2 x 12	2 x 6	2 x 8	2 x 10	2 x 12
		Maximum rafter spans							
		(ft. in.)	(ft. in.)	(ft. in.)	(ft. in.)	(ft. in.)	(ft. in.)	(ft. in.)	(ft. in.)
12	Douglas Fir-Larch SS	11-4	15-0	19-1	23-3	11-4	15-0	19-1	23-3
	Douglas Fir-Larch #1	10-11	14-5	18-5	22-0	10-11	14-2	17-4	20-1
	Douglas Fir-Larch #2	10-9	14-2	17-9	20-7	10-6	13-3	16-3	18-10
	Douglas Fir-Larch #3	8-8	11-0	13-5	15-7	7-11	10-0	12-3	14-3
16	Douglas Fir-Larch SS	10-4	13-7	17-4	21-1	10-4	13-7	17-4	21-0
	Douglas Fir-Larch #1	9-11	13-1	16-5	19-1	9-8	12-4	15-0	17-5
	Douglas Fir-Larch #2	9-9	12-7	15-5	17-10	9-1	11-6	14-1	16-3
	Douglas Fir-Larch #3	7-6	9-6	11-8	13-6	6-10	8-8	10-7	12-4
19.2	Douglas Fir-Larch SS	9-8	12-10	16-4	19-10	9-8	12-10	16-4	19-2
	Douglas Fir-Larch #1	9-4	12-4	15-0	17-5	8-10	11-3	13-8	15-11
	Douglas Fir-Larch #2	9-1	11-6	14-1	16-3	8-3	10-6	12-10	14-10
	Douglas Fir-Larch #3	6-10	8-8	10-7	12-4	6-3	7-11	9-8	11-3
24	Douglas Fir-Larch SS	9-0	11-11	15-2	18-5	9-0	11-11	14-9	17-1
	Douglas Fir-Larch #1	8-8	11-0	13-5	15-7	7-11	10-0	12-3	14-3
	Douglas Fir-Larch #2	8-1	10-3	12-7	14-7	7-5	9-5	11-6	13-4
	Douglas Fir-Larch #3	6-2	7-9	9-6	11-0	5-7	7-1	8-8	10-1

5. Completing Your Framing Section

Items such as the size of all framing members, interior and exterior finishes, as well as the roof and floor covering must be specified on the plan.

The framing sections and details shown in this bulletin are the most commonly used for single story room additions. You may include any illustration shown that relates to your project by completing the blank portions and attaching them to your plans. These illustrations do not reflect all additions or designs and cannot be used in every case.

Figure 1/ Floor Plan with Cross Referenced Section Views
(x 25.4 for mm)

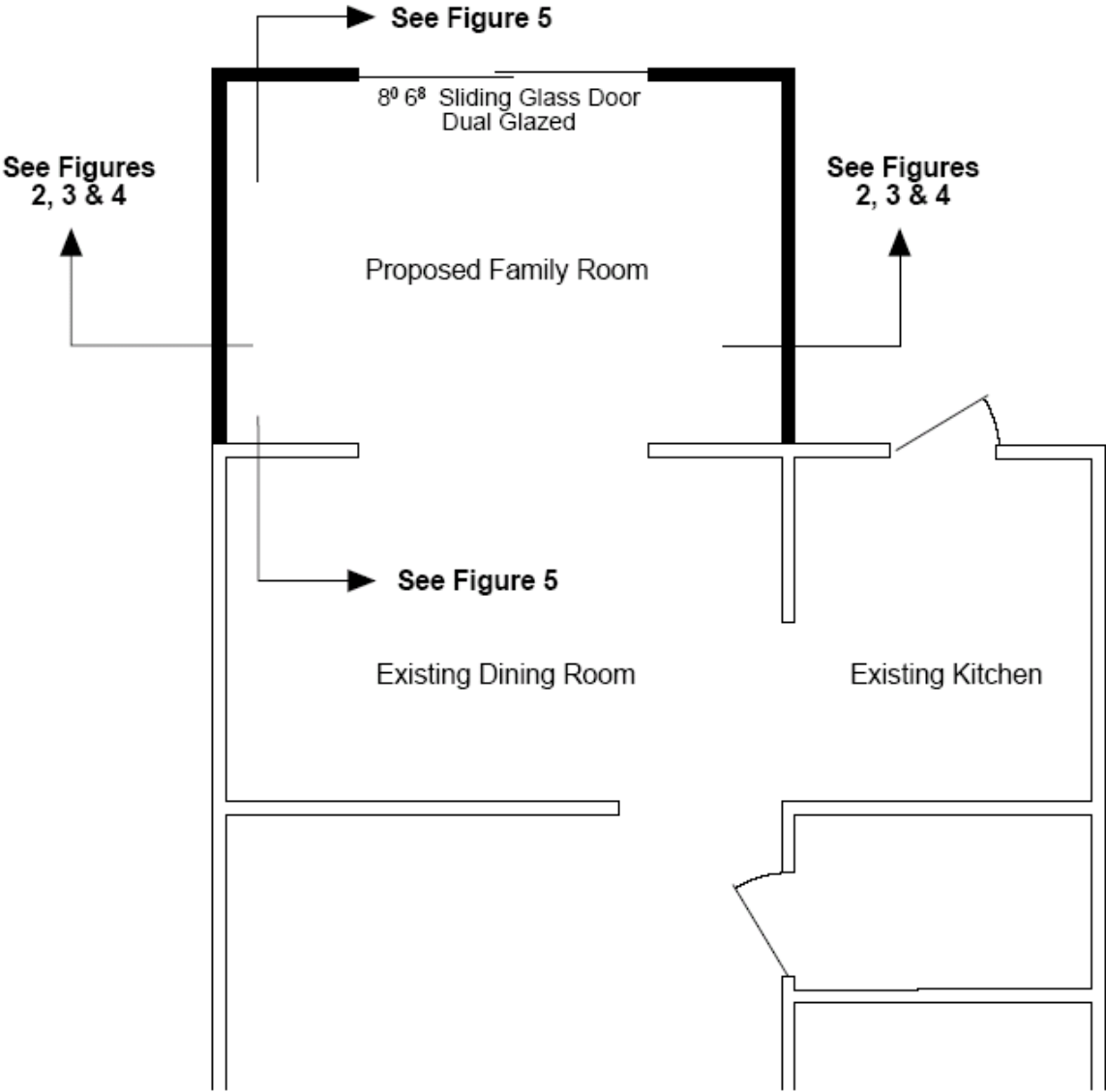

Figure 2/ Typical Cross Section View, Slab Floor with Ceiling Joist
(x 25.4 for mm)

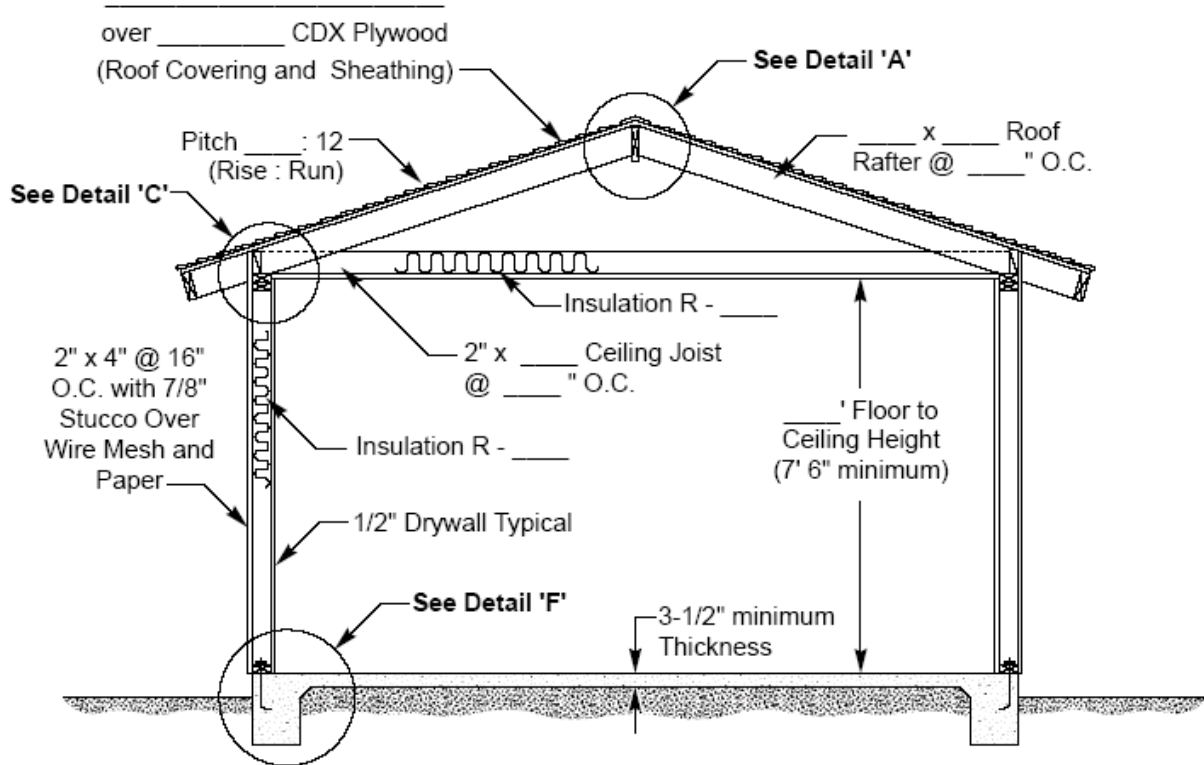

Figure 3/ Typical Cross Section View, Slab Floor with Vaulted Ceiling
 (x 25.4 for mm)

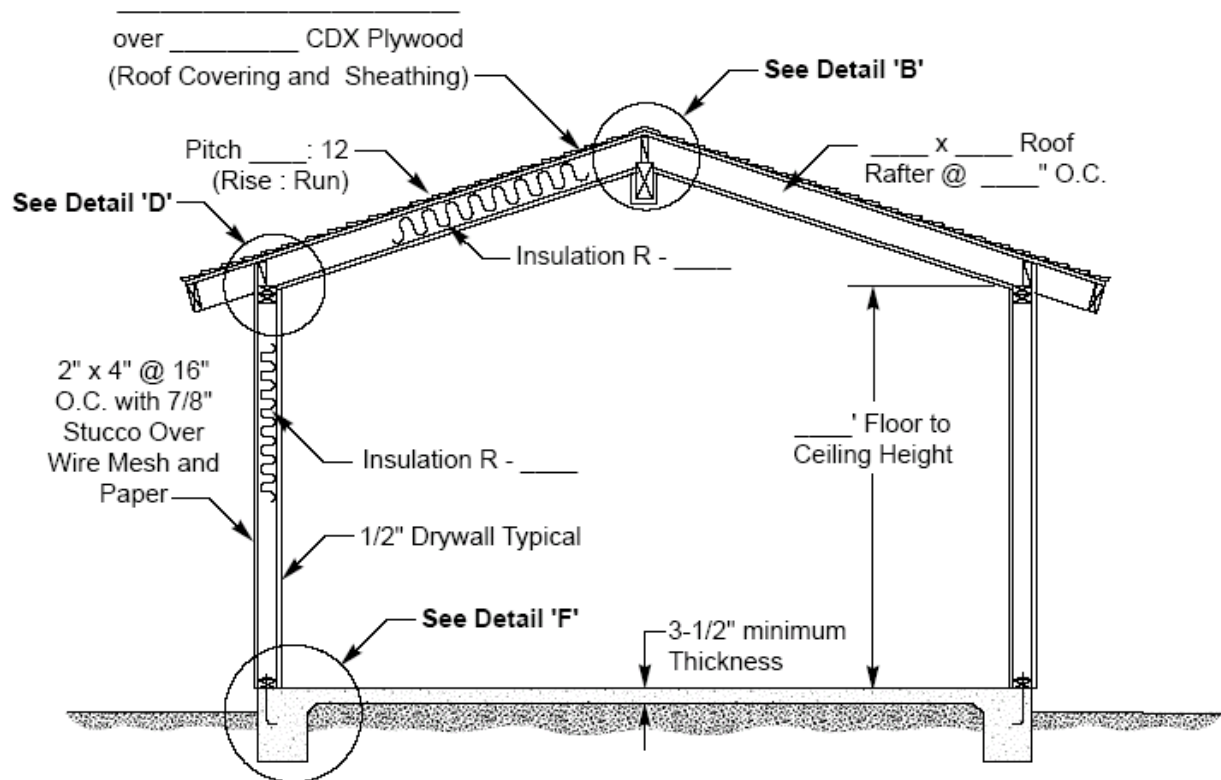

Figure 4/ Typical Cross Section View, Raised Floor with Ceiling Joist
 (x 25.4 for mm)

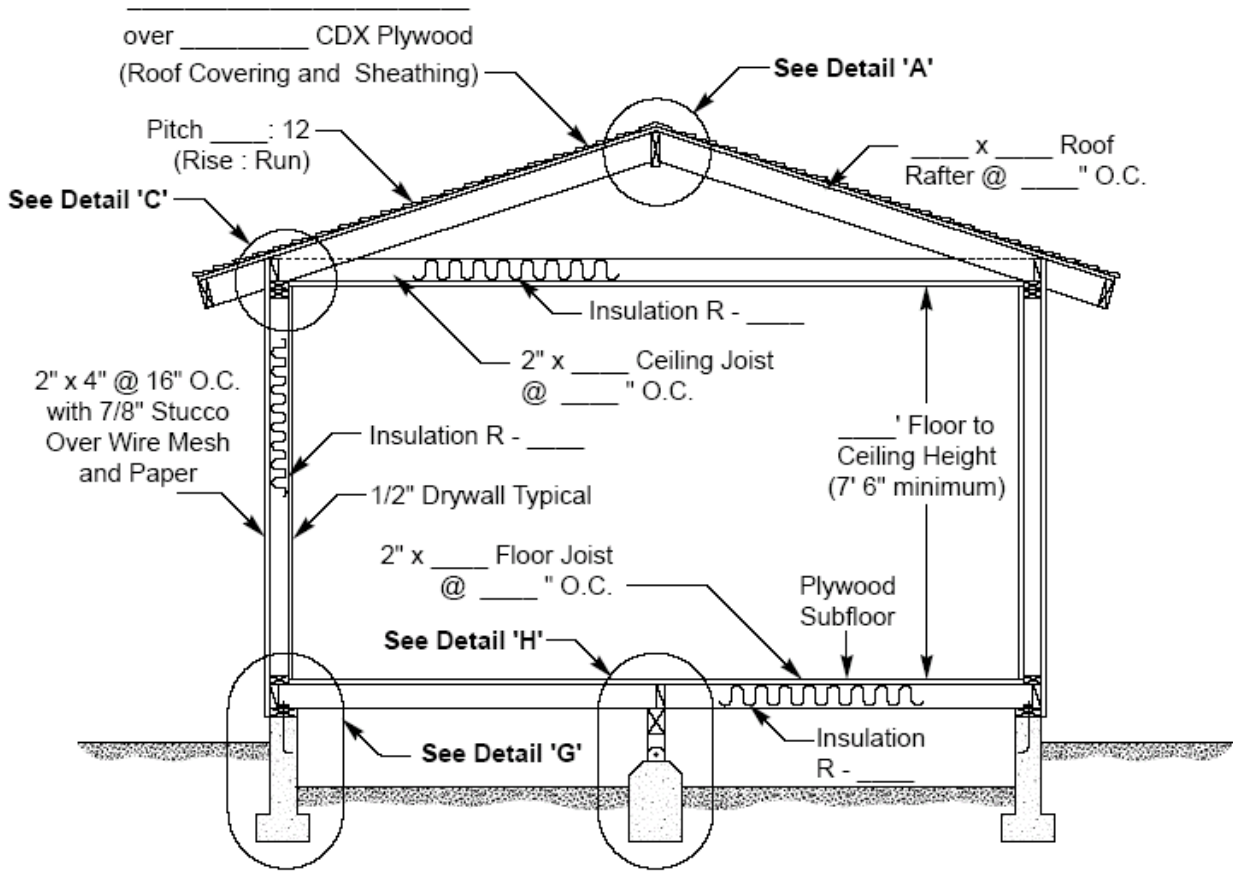
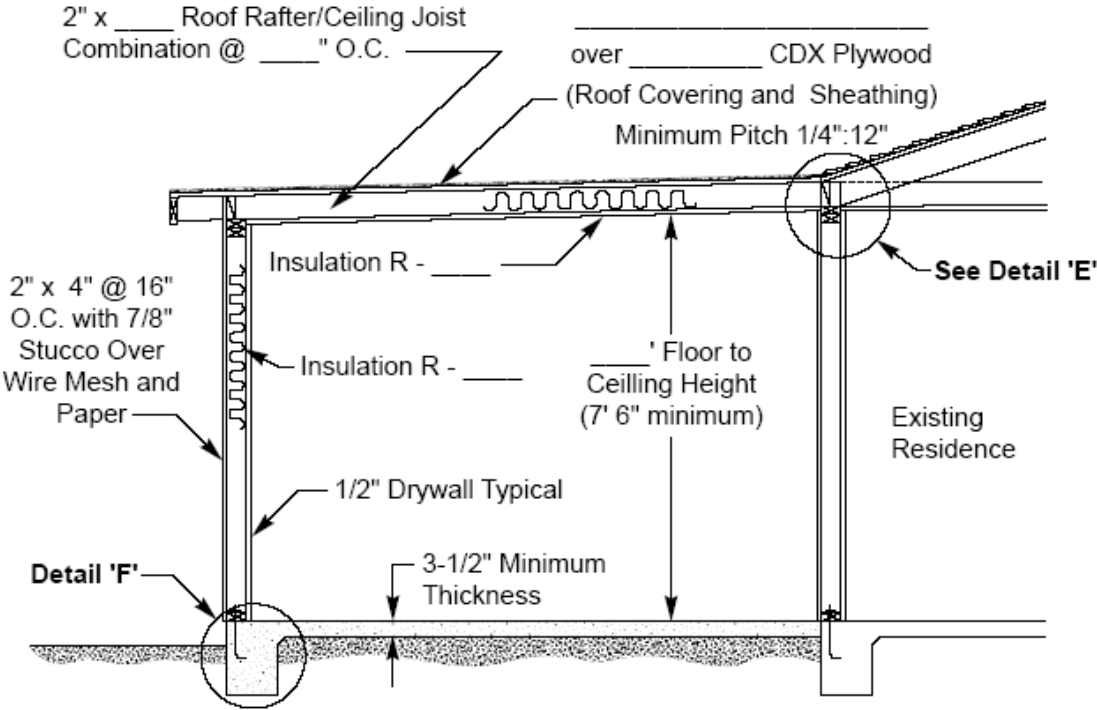
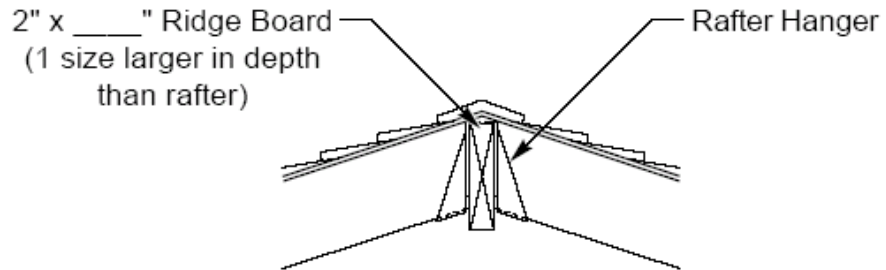

Figure 5/ Typical Cross Section View, Slab Floor with Shed Roof
 (x 25.4 for mm)



Detail "A" / Typical Roof Connection, Non-Load Bearing Ridge
(x 25.4 for mm)



Detail "B" / Typical Roof Connection, Load Bearing Ridge
(x 25.4 for mm)

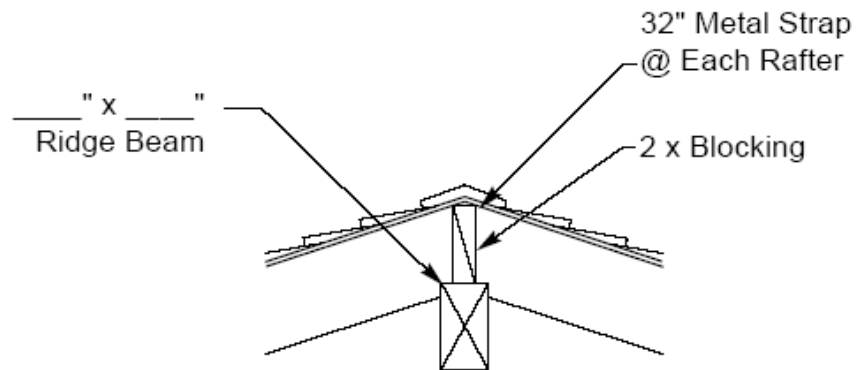

Detail "C" / Typical Roof Connection With Ceiling Joist
(x 25.4 for mm)

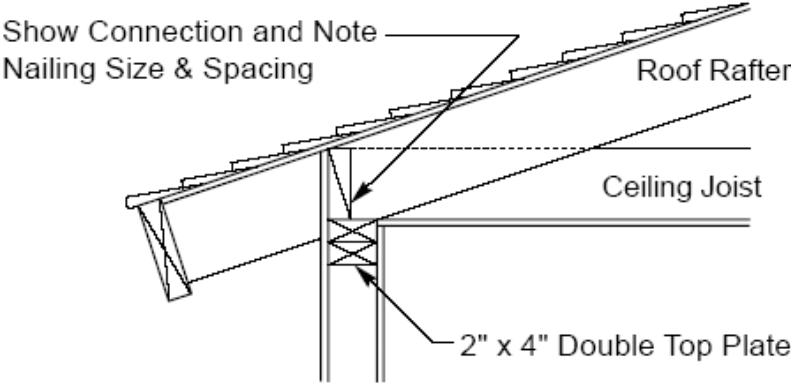

Detail "D" / Typical Roof Connection With Vaulted Ceiling
(x 25.4 for mm)

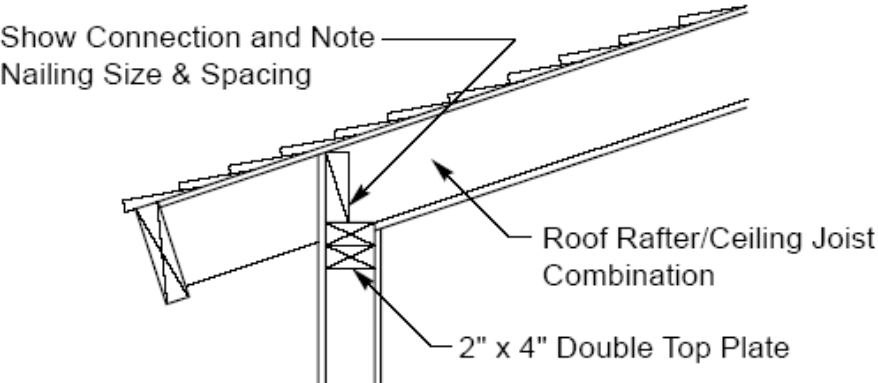

Detail "E" / Typical Roof Connection, Shed Roof
 (x 25.4 for mm)

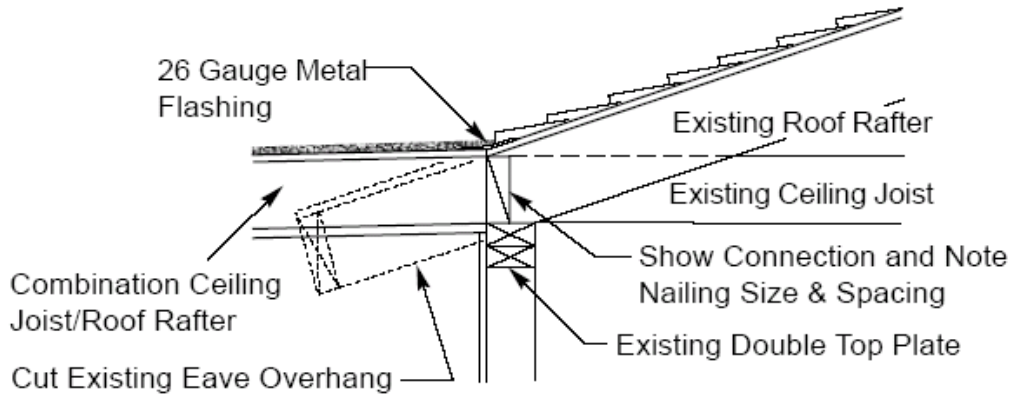

Detail "F" / Typical Floor Connection, Continuous Footing
 (x 25.4 for mm)

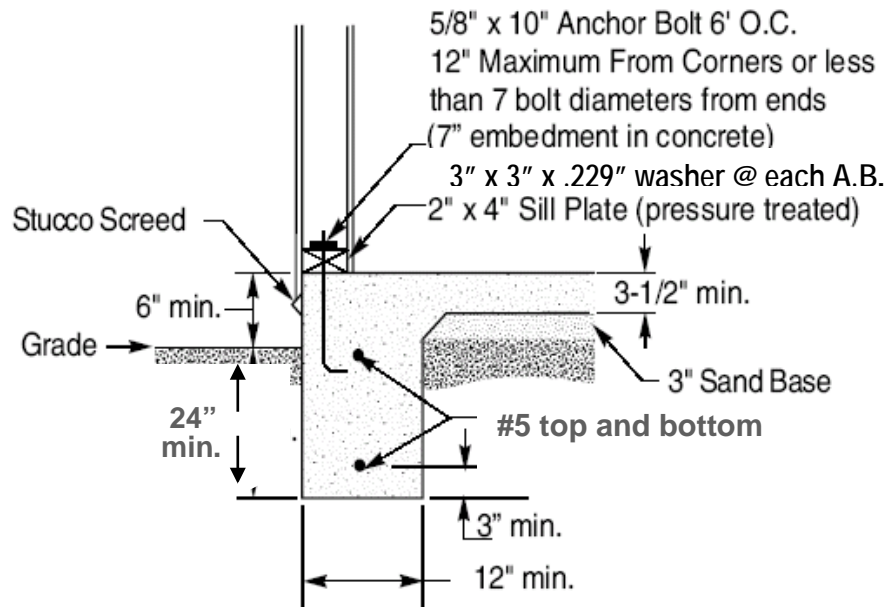

Detail "G" / Typical Floor Connection, Foundation or Stem Wall (x 25.4 for mm)

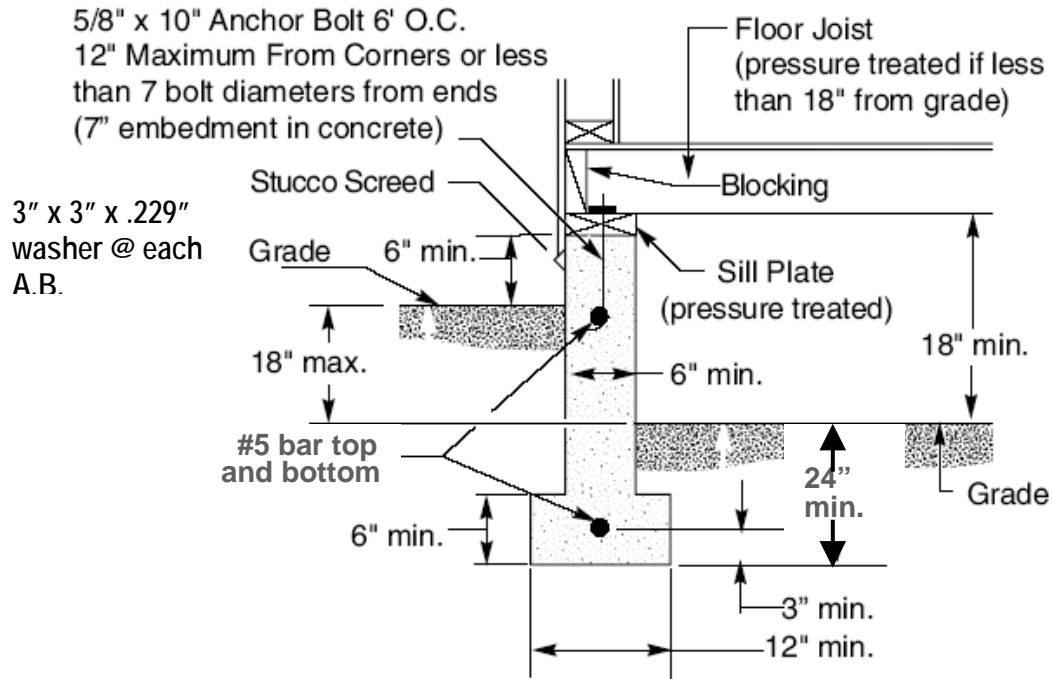

Detail "H" / Typical Floor Connection, Square Pad footing (x 25.4 for mm)

